

AR 194

November 2024

Dutch version

Approval requirement 194

Tools for temporarily closing of gas pipes



**Trust
Quality
Progress**

Foreword

This, translated from Dutch, approval requirement (AR), is approved by the Board of Experts (BoE) GASTEC QA. in which relevant parties in the field of gas related products are represented. This Board of Experts supervises the certification activities and where necessary require the GASTEC QA approval requirement to be revised. All references to Board of Experts in this GASTEC QA approval requirement pertain to the above-mentioned Board of Experts.

This, translated from Dutch, AR will be used by Kiwa Nederland BV in conjunction with the GASTEC QA general requirements and the KIWA regulations for certification.

Kiwa has a method which is established in the certification procedure for the execution of:

- The investigation for provisioning and maintaining a GASTEC QA product certificate based on this AR.
- The periodic evaluations of the certified products for the purpose of maintaining a provided GASTEC QA product certificate based on this AR.

This, translated from Dutch, AR, is used as supporting document. In case of doubt of interpretation of this AR, the Dutch version is leading.

Kiwa Nederland B.V.

Wilmersdorf 50
P.O. Box 137
7300 AC Apeldoorn
The Netherlands

Tel. +31 88 998 33 93
Fax +31 88 998 34 94
info@kiwa.nl
www.kiwa.nl

© 2024 Kiwa Nederland B.V.

All rights reserved. No part of this book may be reproduced, stored in a database or retrieval system, or published, in any form or in any way, electronically, mechanically, by print, photoprint, microfilm or any other means without prior written permission from the publisher.

The use of this approval requirement by third parties, for any purpose whatsoever, is only allowed after a written agreement is made with Kiwa Nederland B.V. to this end

Contents

	Foreword	1
	Contents	2
1	Introduction	4
1.1	General	4
1.2	Scope	4
1.3	Leak criterion - < 10% LEL in a working pit	5
2	Definitions	6
2.1	Parts of the mounting equipment and closing element - gasbladder	8
3	Material and product requirements	10
3.1	Dimensions and materials	10
3.2	Parts	10
3.2.1	General	10
3.2.2	Manometer	10
3.2.2.1	Manometer inflatable closing element	10
3.2.3	Interchange ability of parts	10
3.2.4	Valves	10
3.2.5	Placing of the closing element with use of top piece saddles	10
3.2.6	Double versions of inflatable closing elements	11
3.2.7	Measurement of the pressure in the gas distribution system	11
3.2.8	Un-pressurizing of the pipe part between closing elements	11
3.3	Materials	11
3.3.1	General	11
3.3.2	Metals	11
3.3.3	Rubber parts	11
3.3.4	Resistance against aging	11
4	Performance requirements and test method	12
4.1	General	12
4.1.1	Testing equipment	13
4.1.1.1	Pressure sensor	13
4.1.1.2	Force sensor	13
4.1.1.3	Flow measurement	13
4.1.1.4	Other	13
4.1.2	Appearance	13
4.2	Leak tightness	14
4.2.1	Leak tightness static sealing	14
4.2.1.1	Test method:	14
4.2.2	Leak tightness static sealing between inflatable element and placing unit	14

4.2.2.1	Test method:	14
4.2.3	Leak tightness dynamic sealing	14
4.2.3.1	Test method:	14
4.2.4	Leak tightness closing element: pipe systems inside buildings	14
4.2.4.1	Test method:	15
4.2.5	Leak tightness closing element: pipe systems outside buildings	15
4.2.5.1	Test method – nodular cast iron:	15
4.2.5.2	Test method - PE:	15
4.2.6	Leak tightness connection unit – top piece	15
4.2.6.1	Test method:	16
4.3	In-use tests	16
4.3.1	Bending test	16
4.3.1.1	Test method:	16
4.3.2	Placing and pulling force	16
4.3.2.1	Test method:	16
4.3.3	Slide resistance	17
4.3.3.1	Test method:	17
4.3.4	Resistance against damage	17
4.3.4.1	Resistance to inflation pressure	17
4.3.4.2	Resistance to tightness control before use	17
4.3.4.3	Resistance against static tensile force	18
4.3.4.4	Resistance against repeated use	19
4.3.4.5	Resistance against rupture	19
4.3.4.6	Resistance against gas flow during placing	20
5	Marking and instructions	21
5.1	Marking	21
5.2	Instructions	21
6	Quality system requirements	22
7	Summary of evaluation	23
7.1	Evaluation matrix	23
8	List of referenced documents and source	25
8.1	Standards / normative documents	25
8.2	Source of informative documents	25

1 Introduction

1.1 General

This GASTEC QA approval requirement (AR) in combination with the GASTEC QA general requirements, is applied by Kiwa as the basis for the issuing and maintaining the GASTEC QA product certificate for tools for the temporarily closing of gas pipes.

With this product certificate, the certificate holder can demonstrate to his or her customers that an expert independent organization monitors the production process of the certificate holder, the quality of the product and the related quality assurance.

Next to the requirements established in this AR and the general requirements, Kiwa has additional requirements in the sense of general procedural requirements for certification, as laid down in the internal certification procedures.

This GASTEC QA approval requirement replaces the version of February 2019.

List of changes:

- Adjustment and explanation of the permitted leakage values.
- Textual changes.
- Clarification of the definitions.
- Removal of TBA and calamity bladder.
- Removal of the distinguish between distribution and other lines.

The product requirements have been changed by the adjustment of the permitted leakage values.

1.2 Scope

This approval requirement applies for tools for the temporarily closing of gas distribution pipes with natural gas with a nominal pressure of 100 mbar, included are the distribution pipes in which a temporarily or permanent pressure is of maximal 200 mbar.

The specific function recommendations for the application of equipment for temporarily closing of gas distribution pipes is described in NEN 7244 series and the safety instructions natural gas (VIAG) with the accompanying work instructions (VWI). Also, the instructions / user manual of the supplier shall be followed.

The below table shows an overview of the under this approval requirement included equipment's with their application and characteristics.

Interrupt gas pipes in the distribution net with a nominal operating pressure up to and including 100 mbar.	Replacement of main valve in the distribution net with a nominal operating pressure up to and including 100 mbar.
Equipment in combination with inflatable closing element.	Valve change sets using inflatable closing element.
Equipment using a mechanical closing element	Valve change sets using mechanical closing element

Table 1

1.3 Leak criterion - < 10% LEL in a working pit

As part of the national HyDelta research program, research has been carried out into the suitability of gas bladders as a temporary seal (in a working pit) in the distribution network of the regional grid operator. In this study (HyDelta 2 WP6B), tests were carried out to determine the maximum leakage rate (natural gas and hydrogen) at which the concentration in a working pit is less than 10% LEL.

Regarding natural gas, the measurements carried out show that at 0.15 m³/h a concentration \geq 10% LEL was achieved. In this situation less than 5% of the measurements the concentration was \geq the 10% LEL.

The leakage value is based on a working pit with the dimensions: a depth, length, and width of 1m, 1.7m and 1.2m respectively. The size of the working pit influences, among other things, the measured concentration.

The 10% LEL relates to the working pit. Considering the field of application, a pipeline can be fed from two sides. When a pipe is interrupted, the gas therefore flows from two directions (the outflow openings) into a working pit.

In this AR taken into account are 2 outflow openings for criteria which applies. The permitted leakage quantity is therefore set in this KE at 0.075 m³/h natural gas. See also chapter 4.

2 Definitions

In this approval requirement, the following terms and definitions are applicable:

Attachment: A component that is screwed into a blowhole saddle and in which the lance can be placed correctly above the gas pipe. This attachment is provided with a rubber cover that allows the gas-free drilling and setting of closing elements.

Bladder, gasbladder: Inflatable element for temporarily closing of gas pipes.

Bladder saddle: Special saddle for placing a closer element.

Board of Experts (BoE): The Board of Experts GASTEC QA.

Connection element: The part that provides the connection between the pipe to be sealed and the equipment with the sealing element. This part can form an integrated whole with the equipment for the temporary closing of gas pipes. Examples of a connection element are the connection by an adapter on the attachment, on a tap, on a pipe, etc.

Connection hose: Hose on the inflatable element that forms the connection between the rod and the inflatable element.

Consumption period for consumables (including blowing and other closing devices): Term and conditions the manufacturer specifies regarding use and shelf life.

Closing element: The part with which the pipe is sealed (the inflatable or mechanical sealing element).

Double bladder: Two inflatable shut-off elements, with or without a protective cover, which are physically connected to each other and are considered to be a single shut-off element (one double bladder that can be operated by one pressure gauge rod) but each of which has a separate pressure gauge for inflation and vacuuming.

Dynamic seals: These are seals designed to ensure leak-tightness in moving parts. Examples of this are stuffing boxes / seals / o-rings / fitting seats, etc. which are used with components which move relative to each other during use. This can be turning or sliding as is the case with cranes, slides, retracting lances, or bars etc.

Flexible element: The flexible part in the inflatable element.

Flow: Flow rate of gas per unit time.

Inserting unit: Part to which the connecting pipe of the sealing element is screwed. The rod is constructed in such a way that the sealing element can be pushed out of and into the lance. The rod also provides for an inflatable sealing element to be inflated and vacuum sucked.

Insertion element: The part of the device with which the sealing element is inserted into the pipe. Example of an insertion element is the sliding part of a blowing lance which passes through the adapter to bring the sealing element into the pipe.

Lance: Part that is connected to the insertion element and connected to the connection element, after which the insertion element can move up and down in the lance for the insertion and retraction of the closing element.

LEL: The lower explosion limit.

LFL: the lower flammability limit. Below the lower flammability limit (LFL) , there is insufficient fuel present to sustain a combustion reaction.

Maximum operating pressure (MOP): Maximum pressure that a component is capable of withstanding continuously in service under normal operating conditions.

Mounting equipment: The assembly of parts uses to place and remove the closing element (through the attachment) in the pipe.

Normal use: Normal use is the intended use of the product according to the instructions and condition of the supplier.

Period of use of tools: Period that the manufacturer indicates between two inspections.

Pressure: Overpressure in relation to atmospheric pressure.

Supplier: The party that is responsible for ensuring that products continuously meet the requirements on which the certification is based, being the certificate holder and / or manufacturer.

Test pressure: The pressure prescribed by the manufacturer to be applied during the inspection of inflatable sealing elements.

Working pressure or inflation pressure: The pressure prescribed by the manufacturer that occurs during normal use, for example the pressure in the inflatable element placed in the pipe.

Workload: 90% (\pm 5%) of the maximum stroke to be made in practice.

See also the definitions mentioned in the GASTEC QA general requirements.

2.1 Parts of the mounting equipment and closing element - gasbladder

For the purpose of clarifying the terms used, illustrations and descriptions are given below, see the corresponding number.

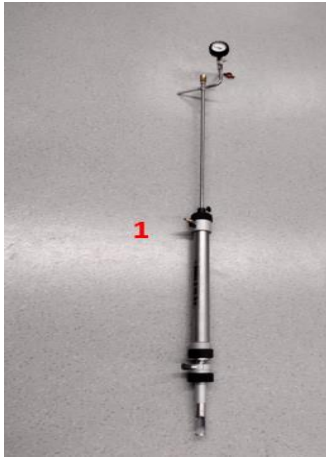

1	<i>The setting tool for inserting and removing gas bladders.</i>
2	<i>The Insertion element with pressure gauge either insertion element or insertion unit.</i>
3	<i>The upper part which concerns the flexible element or the connecting hose and the thread..</i>
4	<i>The lower, red part, a gas bladder or a closing element.</i>
5	<i>A lance.</i>
6	<i>A connecting element. The attachment is part of the connecting element in the illustration.</i>
7	<i>A saddle and high impact PVC pipe in which the bladder is placed.</i>
8	<i>The setting tools, gas bladder and saddle in separate parts.</i>
9	<i>A gas bladder inserted into the tube (with the setting tool).</i>

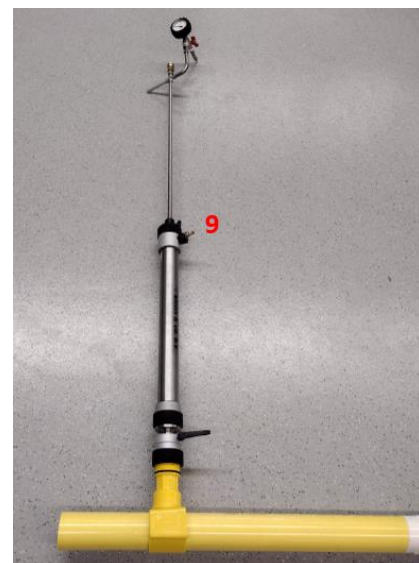
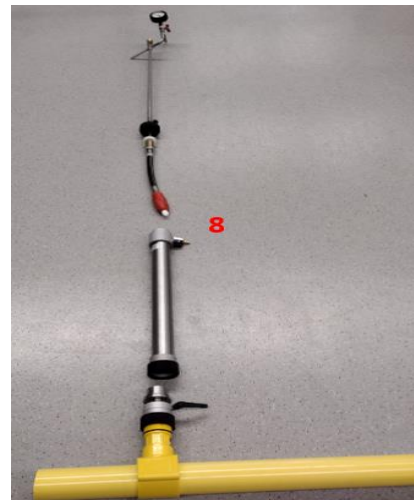
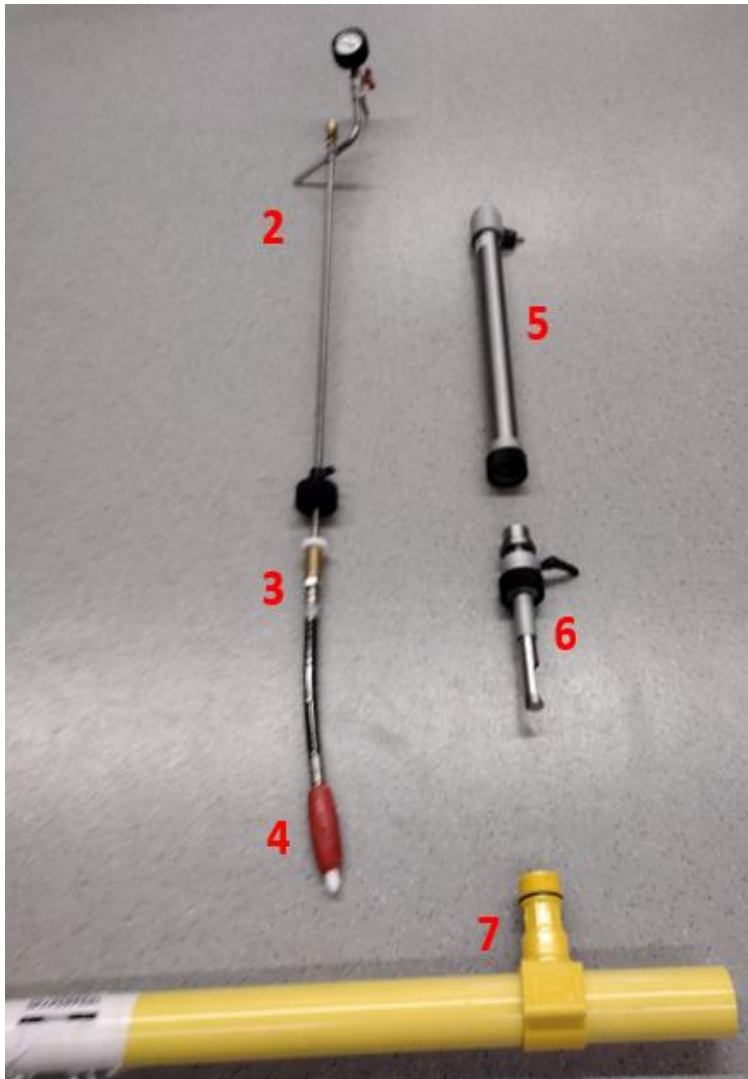

Pictured below (from top to bottom):
Above: the insertion unit with gas bladder (2)
Middle: the lance (1),
Bottom: A saddle and an impact-resistant PVC pipe in which the bladder is inserted (7)



The illustration shows the setting tool in which a bladder is inserted or removed into a transparent tube, (for illustrative purposes the transparent tube has been used).



3 Material and product requirements

This chapter contains the material and product requirements that the raw materials, materials, and products used shall meet.

3.1 Dimensions and materials

The used materials, composition, dimensions, and tolerances of the parts shall comply with the construction drawings of the manufacturer. These drawings shall be provided by the applicant.

3.2 Parts

3.2.1 General

The parts shall be internally and externally clean, smooth finished, free of burs and shall show no sign of defects. Externally sharp corners shall be avoided. This will be checked visually.

Tools and parts shall not fail or show more leakage during the normal use period and storage. The functional properties shall not be negatively influenced during the period of use.

Tools, parts, and devices shall not bring any not intended damage to the gas supplying system. Any used lubricant shall be silicone free.

3.2.2 Manometer

When manometers are used, they shall have a deviation of max 5% Rdg. and shall be clearly readable. When analog manometers are used the nominal pressure should be at 2/3 of the max readable value.

3.2.2.1 Manometer inflatable closing element

The manometers shall have the necessary inflation pressure of the closing element clearly marked. If for functioning of the closing element it is necessary to apply vacuum, the required vacuum shall be clearly marked.

3.2.3 Interchange ability of parts

The construction of the equipment shall be such, that parts which get worn during normal use can be changed by not specialized personnel.

3.2.4 Valves

Valves shall be able to be opened and closed with a quarter turn and shall be maintenance free.

3.2.5 Placing of the closing element with use of top piece saddles

The parts which are necessary to place the closing element through the top piece in the pipe system (placing unit) shall be made that no damage or loss of functionality is brought to the valve and seat of the top piece.

3.2.6 Double versions of inflatable closing elements

When double versions of the inflatable closing element are used, the elements shall be able to be pressurized and controlled on the pressure separated. The construction of double versions shall be such way that the combination closing element, manometer and valve is clear. When the pressure between the 2 closing elements can be measured, the manometer shall comply with paragraph 3.2.7.

3.2.7 Measurement of the pressure in the gas distribution system

When the closing element has ability to measure the pressure in the gas distribution system, the used manometer shall comply with paragraph 3.2.2.

3.2.8 Un-pressurizing of the pipe part between closing elements

When the closing element has ability to un-pressurize the pipe part between closing elements, then the valves shall comply with paragraph 3.2.4.

3.3 Materials

3.3.1 General

The materials for the equipment for temporarily closing of gas pipes shall be chosen that they can resist the, during normal use, occurring influences.

3.3.2 Metals

Metal parts shall be free from corrosion, burs, and other imperfections.

3.3.3 Rubber parts

Rubber sealings shall fulfil the requirements according to EN 682, type GAL or GBL.

3.3.4 Resistance against aging

The manufacturer shall declare the materials are suitable for normal use.

4 Performance requirements and test method

This chapter contains the performance requirements and associated test methods that the products shall meet. This chapter also specifies the limit values, if applicable.

4.1 General

The test methods are intended to test the equipment with worst-case situations that may occur in practice. Should this goal not be achieved with the determination methods included here, then a modified / additional test protocol will be drawn up by the manufacturer in consultation with the certifying body. The certifying body and the manufacturer can take the initiative for this.

The tests are carried out at an ambient temperature of 23 ± 3 °C unless otherwise stated. For the test included in this approval requirement the test medium is pressure air.

Where PE or high impact PVC is mentioned in this approval requirement, GASTEC QA approved PE or high impact PVC products are meant. The work, such as the installation and removal of the closing devices, is carried out in accordance with the method stated in the user manual of the manufacturer.

Unless otherwise stated or initiated by Kiwa Nederland B.V., the tests on sealing elements are performed in triplicate on the smallest, middle and largest of the series.

This way of testing will represent the series but only under the condition that: the sizes of bladders in a series of sizes are made of the same materials at the same location, with the same production processes and the same quality management system. This is considered representative of the size series. If the conditions mentioned above are not met, all dimensions (of bladders) from a size series are subjected to the tests for each measure.

The tests on the placing equipment shall be carried out on each type.

Closure element (for pipes)

Additionally, the tests shall be carried out on each type of lance of the system being presented for inspection.

(Inflatable) closing element

Additionally, the tests to be carried out on a pipe diameter for which the work instructions (VIAG) or manufacturer's instructions prescribe a double sealing element shall also be carried out as such.

Allowed leakage value

As mentioned in Chapter 1, the 10% LEL refers to a working pit with, as assumed in this AR, 2 outflow openings. The permitted leakage quantity, the maximum leakage rate, per installed closing element is 0.075 m³/h for natural gas.

Because the test medium is air, an air: natural gas ratio of 1:1.54 is taken into account in the leak tests in order to calculate the value for this performance requirement. This results in a rounded maximum leakage rate of 50 dm³/h for the leak tests performed with air. See also the table below.

The maximum leakage rate of 50 dm³/h applies to the grid pressures of 30mbar, 100mbar and 200mbar.

Leakage value					
Gas outlet	Natural gas (m ³ /h)	Natural gas (dm ³ /h)	Air (m ³ /h)	Air (dm ³ /h)	Rounded, criterion (dm ³ /h)
2 outflow openings	0.075	75	0.049	49	50

Table 2: stated leakage value for closing elements outside a building

4.1.1 Testing equipment

4.1.1.1 Pressure sensor

The for the tests to be used pressure sensor shall have an inaccuracy of $\pm 5\%$ Rdg. If a tolerance is mentioned with the test, this applies to the with the pressure sensor read value.

4.1.1.2 Force sensor

The for the tests to be used force sensor shall have an inaccuracy of $\pm 5\%$ Rdg. If a tolerance is mentioned with the test, this applies to the with the force sensor read value.

4.1.1.3 Flow measurement

Flows shall be established with an $\pm 5\%$ Rdg.

4.1.1.4 Other

The dimensions of the parts which are important for the functioning shall be checked with suitable tools with a measurement accuracy of at least 0.1 mm.

4.1.2 Appearance

The appearance and finish shall be visually reviewed. No burrs, corrosion, damage, and other imperfections may occur that may adversely affect the operation or cause injury when working with the tools.

4.2 Leak tightness

4.2.1 Leak tightness static sealing

Between the connection of the insertion element and the connecting hose leakage is not allowed, after being made and broken 500 times. This test is aimed at connecting the bladder connection hose and the insertion element.

4.2.1.1 Test method:

1. Assemble and disassemble all types of connections in which the static sealing is located 500 times.
2. Apply a test pressure of 1.5 times the working pressure.
3. Check the leak tightness with a non-aggressive (an according to AR 120 certified) leak detection product. There shall be no leakage visible.

4.2.2 Leak tightness static sealing between inflatable element and placing unit

The seal (where the gas bladder is inserted into a corresponding diameter pipe in a vertical direction) shall not show any leakage after being made and broken 100 times. The gas bladder remains in the vertical tube during the entire cycle (100 times).

4.2.2.1 Test method:

1. Assemble and disassemble all types of connections in which the static sealing is located 100 times.
2. Apply a test pressure of 1.5 times the working pressure.
3. Check the leak tightness with a non-aggressive (an according to AR 120 certified) leak detection product. There shall be no leakage visible.

4.2.3 Leak tightness dynamic sealing

The seal shall show no leakage after 500 times over the entire working stroke (fully inserted and removed) of the parts to be sealed.

4.2.3.1 Test method:

1. Move the sealing parts for 500 times over the total working stroke with a speed as expected in practice.
2. Apply a test pressure of 1.5 times the working pressure.
3. Check the leak tightness with a non-aggressive (an according to AR 120 certified) leak detection product. There shall be no leakage visible.

4.2.4 Leak tightness closing element: pipe systems inside buildings

The maximum leakage between closing element and pipe shall be 5 dm³/h natural gas what correspondents with 3 dm³/h air, when the closing element is placed in a steel pipe. Using the air: natural gas ratio of 1:1.54, the rounded leak criterion of 3 dm³/h air follows.

With inflatable closing elements the inflatable pressure is equal to the working pressure.

4.2.4.1 Test method:

1. Place the closing element in a steel pipe (closing element for other pipes). Bring an inflatable closing element to working pressure.
2. Apply a test pressure of 30 mbar.
3. Maintain this situation for 30 ± 5 minutes. The pressure of the closing element shall not be changed during testing.
4. Measure the leakage next to the closing element.
5. Repeat the above process with a pressure of 100 and 200 mbar.

4.2.5 Leak tightness closing element: pipe systems outside buildings

The maximum leakage between closing element and pipe shall be 75 dm³/h natural gas what corresponds with 50 dm³/h air (obtained by the ratio of air to natural gas of 1: 1.54), when the closing element is placed in a nodular cast iron pipe.

This test is not carried out in a PVC HI pipe because PVC HI does not occur/is desirable in pipe networks intended for pressures higher than 200mbar.

4.2.5.1 Test method – nodular cast iron:

1. Place the closing element in a nodular cast iron. Bring an inflatable closing element to working pressure.
2. Apply a test pressure of 30 mbar.
3. Maintain this situation for 30 ± 5 minutes. The possible pressure of the closing element shall not be changed during testing.
4. Measure the leakage next to the closing element.
5. Repeat the above process with a pressure of 100 and 200 mbar.

4.2.5.2 Test method - PE:

The maximum of leakage of the closing element – pipe shall be 75 dm³/h natural gas what corresponds with 50 dm³/h air, when the closing element is placed in a PE-pipe who at the placement of the closing element is pressed oval for 10%.

1. Place the closing element in a PE-pipe which is at the placement of the closing element oval pressed by $10 \pm 1\%$. Bring an inflatable closing element to working pressure.
2. Apply a test pressure of 30 mbar.
3. Maintain this situation for 30 ± 5 minutes. The possible pressure of the closing element shall not be changed during testing.
4. Measure the leakage next to the closing element.
5. Repeat the above process with a pressure of 100 and 200 mbar.

4.2.6 Leak tightness connection unit – top piece

After placing the connection unit 5 times by the valve seat of a top piece the sealing between the connection unit and the top piece shall be leak tight. During placing or removing the maximal air leakage shall not exceed 1 dm³.

4.2.6.1 Test method:

1. Bring the part under the non-return valve of the (GASTEC QA marked) top piece up to 300 mbar.
2. Check if the non-return valve functions normally.
3. Place the lance manually with a normal use speed.
4. Measure during the placing and pulling of the lance the amount of air escaping. This should be less than 1 dm³ each operation.
5. Test, after placing the lance with the connection element for the fifth time, the leak tightness of the placing element – top piece with a non-aggressive (an according to AR 120 certified) leak detection product. There shall be no leakage visible.
6. Inspect visually the valve seat and check valve. These shall not be damaged, and the valve shall close.

4.3 In-use tests

4.3.1 Bending test

After applying a force of 100 N during 5 minutes on the placing element the parts shall not show any damages. The force shall be applied on the point that results in the largest possible bending moment.

4.3.1.1 Test method:

Below test shall be executed on a high impact PVC-pipe upon which a high impact PVC-Saddle with top piece is mounted.

1. Place the connection element in the top piece. The placing unit is entirely stretched.
2. Apply a force of 100 N. The applied force shall result in the maximum bending moment (extended position of the insertion element).
3. Maintain this situation for 5 minutes ± 30 seconds.
4. Remove the force and inspect the parts visually. The parts shall not be damaged.

4.3.2 Placing and pulling force

Closing element (for pipes)

The force for placing and pulling of the closing element shall not be higher than 230 N. The placing and pulling of the closing element shall take maximal 5 minutes each.

4.3.2.1 Test method:

The next test shall be carried out using the biggest allowed closing element for the smallest allowed pipe combination.

1. Place the closing element in the pipe. Measure the applied force.
2. Measure the time needed for placing.
3. Bring an inflatable closing element on working pressure.
4. Leave the closing element for 4 hours ± 5 minutes in the pipe.
5. Pull the closing element out of the pipe. Measure the applied force.
6. Measure the time needed for pulling the closing element.

4.3.3 Slide resistance

The closing element (depending on the version in combination with the insertion unit) placed in a high impact PVC pipe or PE pipe shall not slide visually during 1 hour with a pressure of 1.5 times the MOP in the pipe. The placement is according to the manufacturer's instructions.

This test will not be performed in a cast iron pipe due to the higher wall roughness which is likely to affect the result.

For inflatable closing elements the working pressure shall not be adjusted during testing.

4.3.3.1 Test method:

1. Place the closing element with the placing unit in a high impact PVC pipe or PE pipe. With inflatable closing elements the inflation pressure is equal to the working pressure
2. Apply a pressure of 1.5 times MOP of the pipe, on one side of pipe.
3. Determine after stabilizing the test set up the position of the closing element.
4. Maintain the test pressure for 1 hour \pm 10 minutes.
5. Determine the position again of the closing element.

4.3.4 Resistance against damage

4.3.4.1 Resistance to inflation pressure

The inflatable closing element shall be able to resist 3 times the working pressure for 30 minutes. The inflatable element shall be supported by the pipe during the test. The closing element shall not succumb as a consequence of testing. The pressure shall not decrease during the test.

4.3.4.1.1 Test method:

1. Place the inflatable element in a pipe with the largest diameter for which the closing element is suitable.
2. Apply the inflatable element to 3 times the working pressure.
3. Wait for 60 ± 5 seconds and note down the pressure.
4. Wait another 30 ± 5 minutes and note down the pressure again.

4.3.4.2 Resistance to tightness control before use

The inflatable closing element shall be able to resist 1.25 times the test pressure. The inflatable element is not supported by the pipe during the test, unless otherwise stated by the manufacturer. The closing element shall not show any damages after the test. The pressure shall not decrease during the test.

4.3.4.2.1 Test method:

1. Apply the inflatable element to 1.25 times the test pressure (pressure before leak tightness control)
2. Wait for 60 ± 5 seconds and note down the pressure.
3. Wait another 30 ± 5 minutes and note down the pressure again.

4.3.4.3 Resistance against static tensile force

The connection between placing unit and closing element for distribution pipelines shall resist a tensile force of 800 N during a period of 5 minutes without any damage.

4.3.4.3.1 Test method:

1. Insert the inflatable sealing element first into the pipe at the working pressure.
2. Apply a force to the connection placing unit/closing element of 800 N following figure 4. Apply working pressure first on an inflatable closing element.
3. Maintain this situation for 5 minutes \pm 30 seconds.
4. Remove the load and inspect the element visually.
5. If applicable, repeat the test for a double inflatable element.

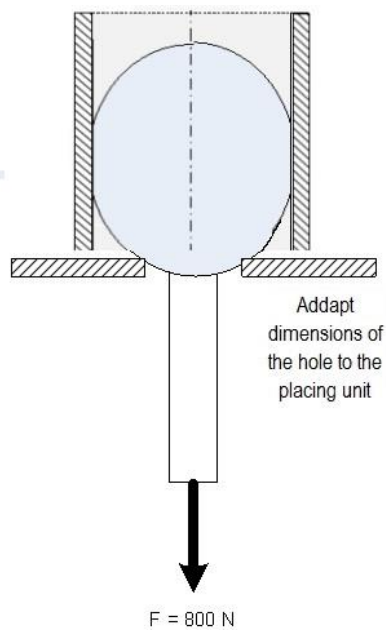

Figure 4

4.3.4.4 *Resistance against repeated use*

Closing element (for pipes)

The part of the closing element which closes off the pipe shall still be functional after 50 times being placed in a nodular cast iron pipe.

Based on the worst-case scenario in which the closing element in a cast iron pipe can be damaged faster than in a PE / PVC HI pipe system, this test is only performed in a ductile cast iron pipe.

Parts with restricted lifetime shall be replaced according to the manufacturer's instructions. After the test the closing element shall fulfil the requirements of paragraph 4.2.5 (only nodular cast iron pipe).

If flexible elements are used, the manufacturer shall declare that the bending radius that results (when installing) is smaller than the bending radius that results from the smallest applicable pipe diameter. The diameter of the pipe shall correspond to the smallest possible pipe diameter to be sealed for which the relevant closing element is suitable.

The setting direction of the closing element shall correspond with the desired direction after insertion.

4.3.4.4.1 *Test method:*

1. Place the closing element in a nodular cast iron pipe with a for the applicable closing element smallest possible internal pipe diameter.
2. Apply a working pressure on the inflatable closing element.
3. remove the inflatable closing element.
4. Repeat the in the first part mentioned step 5, 50 times.
5. Check if needed the placement direction twice, after the first time placing and after the last time placing. This shall correspond with the predetermined direction.
6. Subject the closing element to the test as described in paragraph 4.2.5.

4.3.4.5 *Resistance against rupture*

Inflatable closing elements

If in a closing element, which has a working pressure, a hole of 1 mm is made, this hole shall not grow with a constant pressure.

4.3.4.5.1 *Test method*

1. Apply a working pressure on the closing element in a pipe.
2. Make a hole with a diameter of 1 mm in the closing element on the place as mentioned in figure 5.
3. Apply the working pressure for 1 minute \pm 10 seconds on the closing element.
4. Inspect the closing element visually.

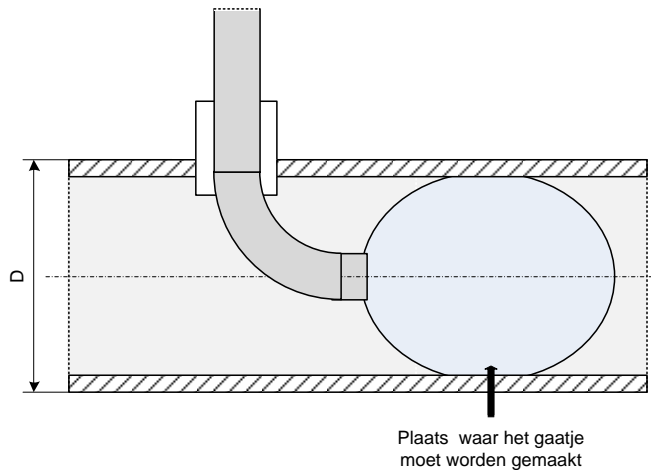

Figure 5 “Plaats waar het gaatje moet worden gemaakt” = place where the hole shall be made

4.3.4.6 Resistance against gas flow during placing

Closing element for distribution lines

The connection between placing unit and closing element shall resist the force occurring during placing of the closing element in a gas flow of 20 m/s. this test is repeated 5 times.

After the test the closing element shall fulfil the requirements of paragraph 4.2.5.1. This test is carried out in a PVC HI pipe because PVC HI is most common/desired in pipe networks intended for pressures equal to and lower than 200 mbar.

4.3.4.6.1 Test method

Below test shall be carried out on a high impact PVC pipe with the largest diameter for which the closing element is suitable and upon which a high impact PVC saddle with top piece is mounted for closing elements for main lines.

1. Create an air speed (or gas speed) of 20 m/s in the pipe.
2. Place the closing element according to the manufacturer's instructions in the pipe.
3. Check, if applicable, the placement direction after the first time placing and after the last time placing. This should comply with the predetermined direction.
4. Repeat this 5 times.
5. Subject the closing element finally to paragraph 4.2.5.

Alternative

Closing element for distribution lines

Alternatively, the connection between placing unit and closing element shall resist 1.5 times the calculated force occurring during placing of the closing element in a gas flow of 20 m/s with a minimum of 800 N. This test is repeated 5 times. (see paragraph 4.3.4.3)

5 Marking and instructions

5.1 Marking

On the equipment (and loose parts) the following shall be durable affixed:

- Name of the manufacturer
- Production date eventually in code.
- The GASTEC QA logo, word, or trademark.
- At inflatable closing elements the working pressure.
- In case closing elements are intended for use inside buildings this shall be marked as such.

Additional for closing elements for pipe systems:

- The pipe system diameter or diameter range for which the closing element is suitable.

5.2 Instructions

The applicant of the approval shall provide a user manual. In this manual minimal following shall be laid down:

- The right use of the equipment.
- The reference to and additions on the specific functional recommendation described in the VWI (safety work instruction) G-24 of the VIAG.
- The right way of control, preparation placing and removing of the closing element.
- The right combination of parts with their dimension range shall be indicated clearly.
- Point of particular interest shall be the avoiding of problems.
- The type of pipe (Cast iron, high impact PVC, PE) and the MOP of the pipe in which the tool may be used.
- The most important points of particular interest shall be mounted non-erasable in the box or case.
- The way of storage and handling of the equipment.
- The period of use of the equipment.
- If applicable the number of applications of (parts) of the closing element.
- The maintenance and control on the equipment necessary to ensure safe working. Among what a summary of parts and the way how these shall be inspected.
- The user's manual shall be provided with (revision) date and document number.

The manual shall be in Dutch language in clearly expressions eventually with pictures. If the product is not marketed in the Netherlands, the manual will in any case be delivered in English and in the national language of the country in which the product is used.

In addition: in the manual shall also be included how and when the maintenance of the equipment shall be carried out and by whom the maintenance of the equipment can be carried out.

6 Quality system requirements

The requirements for the quality system are described in the GASTEC QA general requirements. An important part of this are the requirements for drawing up a risk analysis (e.g., an FMEA) of the product design and the production process in accordance with chapters 3.1.1.1 and 3.1.2.1. This risk analysis shall be available for inspection by Kiwa.

7 Summary of evaluation

This chapter contains a summary of tests to be carried out during:

- The initial product assessment;
- The periodic product verification;

7.1 Evaluation matrix

Description of requirement	Clause	Test within the scope of		
		Initial product assessment	Product verification Verification	Frequency
Product requirements				
Dimensions and materials	3.1	X	X	Each year
Parts	3.2			
General	3.2.1	X		
Manometer	3.2.2	X		
Interchangeability of parts	3.2.3	X		
Valves	3.2.4	X	X	Each year
Placing of closing elements with use of top piece saddles	3.2.5	X		
Double versions of inflatable closing elements	3.2.6	X		
Measurement of the pressure in the gas distribution system	3.2.7	X		
Un-pressurizing the pipe parts between closing elements	3.2.8	X		
Materials	3.3			
General	3.3.1	X		
Metals	3.3.2	X	X	Each year
Rubber parts	3.3.3	X	X	Each year
Resistance against aging	3.3.4	X		
Performance requirements	4			
General	4.1			
Leak tightness	4.2	X		
Leak tightness static sealing	4.2.1	X	X	Each year
Leak tightness static sealing between inflatable element and placing unit	4.2.2	X	X	Each year
Leak tightness dynamic sealing	4.2.3	X	X	Each year
Leak tightness closing element – pipe systems inside buildings	4.2.4	X		
Leak tightness closing element – pipe systems outside buildings	4.2.5	X		
Leak tightness placing unit – top piece	4.2.6	X	X	Each year

Description of requirement	Clause	Test within the scope of		
		Initial product assessment	Product verification	
			Verification	Frequency
In-use test	4.3			
Bending test	4.3.1	X		
Placing and pulling force	4.3.2	X		
Slide resistance	4.3.3	X	X	Each year
Resistance against damage	4.3.4	X		
Resistance against inflation pressure	4.3.4.1	X	X	Each year
Resistance to tightness before use	4.3.4.2	X	X	Each year
Resistance against static tensile force	4.3.4.3	X	X	Each year
Resistance against repeated use	4.3.4.4	X		
Resistance against rupture	4.3.4.5	X	X	Each year
Resistance against gas flow during placing	4.3.4.6	X		
Marking	5.1	X	X	Each year
Instructions (user manual)	5.2	X		

8 List of referenced documents and source

8.1 Standards / normative documents

All normative references in this Approval Requirement refer to the editions of the standards as mentioned in the list below.

NEN 7244-Series	Gas supply systems - Pipelines for maximum operating pressure up to and including 16 bar
EN 682: 2002	Elastomeric seals - Materials requirements for seals used in pipes and fittings carrying gas and hydrocarbon fluids

8.2 Source of informative documents

Hydelta 2 WP6B – Safety – suitability of assets and Working Methods – 24-04-23

D6B.2A - Report on ignition scenarios when using inflatable gas stoppers // D6B.2B - Report on ignition test results

Veiligheidsinstructie Aardgas (safety instructions natural gas)

De VeiligheidsInstructie AarGas voor de Energiebedrijven – www.beiviag.nl/viag

Veiligheidswerkinstructie (safety work instruction) G-24 – 15-04-2023

Gasblazen in LD-leidingen veilig plaatsen en verwijderen

General requirements
GASTEC QA