

AR 69-1

October 2024

Approval requirement

69-1

Manually operated ball valves and closed bottom taper plug valves for gas installations for buildings



**Trust
Quality
Progress**

Foreword

This approval requirement (AR) is approved by the Board of Experts (BoE) GASTEC QA, in which relevant parties in the field of gas related products are represented. This Board of Experts supervises the certification activities and where necessary require the GASTEC QA approval requirement to be revised. All references to Board of Experts in this GASTEC QA approval requirement pertain to the above-mentioned Board of Experts.

This AR will be used by Kiwa Nederland BV in conjunction with the GASTEC QA general requirements and the KIWA regulations for certification.

In this AR is established which requirements a product and the requestor/ certificate holder of the GASTEC QA product certificate should meet and the matter to which Kiwa evaluates this.

Kiwa has a method which is established in the certification procedure for the execution of:

- The investigation for provisioning and maintaining a GASTEC QA product certificate based on this AR.
- The periodic evaluations of the certified products for the purpose of maintaining a provided GASTEC QA product certificate based on this AR.

Approved by the Board of Experts: 29/10/2024

Accepted by Kiwa Nederland B.V.: 05/11/2024

Kiwa Nederland B.V.

Wilmersdorf 50
P.O. Box 137
7300 AC Apeldoorn
The Netherlands

Tel. +3188 998 33 93
Fax +3188 998 34 94
info@kiwa.nl
www.kiwa.nl

© 2024 Kiwa Nederland B.V.

All rights reserved. No part of this book may be reproduced, stored in a database or retrieval system, or published, in any form or in any way, electronically, mechanically, by print, photoprint, microfilm or any other means without prior written permission from the publisher.

The use of this approval requirement by third parties, for any purpose whatsoever, is only allowed after a written agreement is made with Kiwa to this end

Contents

Foreword	1	
Contents	2	
1	Introduction	4
1.1	General	4
1.2	Scope	4
2	Definitions	5
3	Material and product requirements	6
3.1	General	6
3.2	Nominal diameters	6
3.3	Reaction to fire	6
3.4	Operation	6
3.5	Materials for valve knobs or handles	6
3.6	Sealing of passages	6
3.7	Rubber materials	6
3.8	Connections	7
3.8.1	Inlet connection	7
3.8.2	Outlet connection	7
4	Performance requirements and test methods	9
4.1	Leak-tightness in locked position	9
4.2	Operating Torque	9
4.3	Resistance against torsion of union connections	9
4.3.1	Test method	10
4.3.2	Additional test	10
4.4	Endurance	10
4.5	Resistance to low temperature	10
4.6	Resistance to high temperatures	10
4.6.1	Test method	10
5	Marking, instructions and packaging	12
5.1	Marking	12
5.2	Instructions	12
5.3	Packaging	12

6	Quality system requirements	13
7	Summary of evaluation	14
7.1	Evaluation matrix	14
8	List of referenced documents and source	15
8.1	Standards / normative documents	15
8.2	Source of informative documents	16

1 Introduction

1.1 General

This GASTEC QA approval requirement (AR) in combination with the GASTEC QA general requirements, is applied by Kiwa as the basis for the issuing and maintaining the GASTEC QA product certificate for manually operated ball valves and closed bottom taper plug valves for gas installations for buildings.

With this product certificate, the certificate holder can demonstrate to his or her customers that an expert independent organization monitors the production process of the certificate holder, the quality of the product and the related quality assurance.

Next to the requirements established in this AR and the general requirements, Kiwa has additional requirements in the sense of general procedural requirements for certification, as laid down in the internal certification procedures.

This GASTEC QA approval requirement replaces the version of September 2019.

List of changes:

- These approval requirements have been fully reviewed textually.
- Update of list of referenced documents

The product requirements have not changed.

1.2 Scope

This approval requirement specifies the requirements for manually operated ball valves and closed bottom taper plug valves for domestic and commercial installations not directly buried, inside or outside of buildings, using gases of the second and third family as specified in EN 437. The maximum working pressure of the manually operated ball valves and closed bottom taper plug valves is 0,2, 0,5, 1, 5 or 20 bar.

The specific functional recommendations for application of these valves are described in the requirements and measuring methods NEN 1078 and EN 15001-1.

Manually operated ball valves can be applied in the following field of application:

- Used in gas installations for separating different section. In this application NEN 1078 applies for gas installations in buildings and EN 15001-1 applies for industrial gas installations
- Used as a connecting tap in connecting lines with appliances. For this application the Dutch code of practice NPR 3378-11 applies.
- Used as a main stop for service connections by utility services, upstream the gas meter and pressure regulator (if any) in distribution systems. In this application NEN 7244-10 applies.

2 Definitions

In this approval requirement, the following terms and definitions are applicable:

Board of Experts (BoE): The Board of Experts GASTEC QA.

Maximum operating pressure (MOP): Maximum pressure that a component is capable of withstanding continuously in service under normal operating conditions.

See also the definitions mentioned in the GASTEC QA general requirements.

3 Material and product requirements

This chapter contains the requirements for the properties of the raw materials, materials and semi-products used during the production of the products to be certified under this AR.

3.1 General

The products shall comply with EN 331 “Manually operated ball valves and closed bottom taper plug valves for gas installations for buildings”.

Additionally, the products shall comply with the following paragraphs.

3.2 Nominal diameters

The admissible nominal connection sizes (DN) for the valves in this AR are: 6, 8, 10, 12, 15, 20, 25, 32, 40 and 50.

3.3 Reaction to fire

Contrary to EN 331, article 4.1, the manually operated ball valves and closed bottom taper plug valves shall meet the requirements of clause 4.6 of this AR.

3.4 Operation

In addition to EN 331, article 4.2.10, breakage or removal of the valve knob or handle may never lead to leakage of the valve. It shall be possible, if required with the help of auxiliary tools, to operate the valve in case of absence of the knob or handle.

3.5 Materials for valve knobs or handles

The knob or handle shall be made of metal or plastic. If the knob or handle is made of plastic, the valve should be tested according to clause 4.6 of this AR. The material should be self-extinguishing within 5 seconds.

3.6 Sealing of passages

Passages between movable parts of gas conducting spaces and the environment shall not be sealed with the help of re-adjustable packing bushes. The sealing construction in the valve shall ensure good sealing in all valve positions i.e. any position between open and closed and in the locked position.

3.7 Rubber materials

In addition to EN 331, clause 4.2.1.4, the elastomeric sealing material shall comply with EN 549, minimum class A2 or with EN 682, type GAL or GBL.

3.8 Connections

In addition to EN 331, article 4.2.12, it is permitted to provide the valve with one of the following connections. The connections must comply with the relevant requirements or standards. Threaded inlet and outlet connections for valves with pressure-tight joints, made on the threads, shall conform EN 10226-1.

3.8.1 Inlet connection

- Couplings for full end-load mechanical joints in polyethylene pipeline systems, shall be in accordance with GASTEC QA approval requirements 70.
- Compression fittings for connecting copper tubes, shall be in accordance with GASTEC QA approval requirements 35.
- Press fittings for joints in copper and metal gas pipes, shall be in accordance with GASTEC QA approval requirements 186.

3.8.2 Outlet connection

- Compression fittings for connecting copper tubes, shall be in accordance with GASTEC QA approval requirements 35.
- Press Fittings for joints in copper and metal gas pipes, shall be in accordance with GASTEC QA approval requirements 186.
- Union couplers shall be in accordance with NEN 2541, NEN 2542, NEN 2544 and a rubber gasket with dimensions according to NEN 2545 and hardness according to EN 549 class H3.

If a construction is used to secure the union nut behind the liner, other than specified in the NEN 2542 and NEN 2544, then at least the following dimensions specified in the NEN 2542 and NEN 2544 shall be maintained:

The liner (figure 2):

- Dimensions d_4 , d_3 , d_2 , dimensions of detail A and when grip areas for mounting are necessary v , w , t , u or s , h and g , sizes as mentioned in NEN 2542.
- The maximum bore shall be equal to or more than dimension d_1 .

The union nut (figure 3):

- Dimensions s and m (the thread shall be according to ISO 228-1)
- The minimum total high of the key face shall be equal to or greater than length p .
- After mounting the gasket it shall be possible to screw the swivel nut (with thread "t") on the thread (l) of the valve part (figure 1) with a minimum thread length of $\frac{3}{4} \times l$.

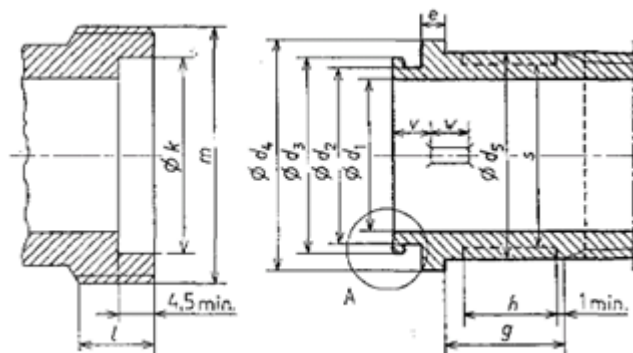

Figure 1: valve part

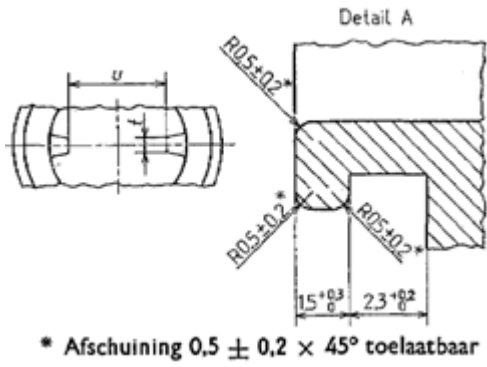

Figure 2: Liner

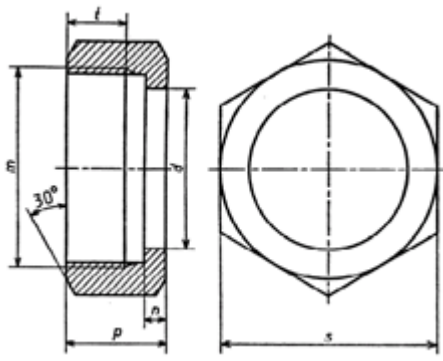

Figure 3: Union nut

All dimensions can be found in NEN 2541, NEN 2542, NEN 2544 and NEN 2545.

4 Performance requirements and test methods

In addition to the requirements from EN 331, the following requirements shall be met.

4.1 Leak-tightness in locked position

In addition to EN 331, article 5.2, the external and internal leak-tightness should also be measured with the knob or handle of the valve in the "locked closed" position.

4.2 Operating Torque

Contrary to EN 331, article 4.7, the operating torque may not exceed the values as given in table 1.

DN	Torque (Nm)
	Ambient and low temperature max.*
≤ 15	1
20	1
25	1,8
32	4
40	7
50	10

Table 1: Operation torque

*The torque required for the preliminary cycle must not be greater than three times the maximum value at ambient temperature given for the size of the valve.

4.3 Resistance against torsion of union connections

In addition to EN 331, article 4.7.2, the union coupler shall resist a torque according to table 2, applied on the union nut. Under the test circumstances according to paragraph 4.3.1 below, the union connection may not show any permanent deformations and/or damage and it shall be gastight when tested according to EN 331, article 5.2.

Dimension m nut	Torsion moment in Nm 10 s test
½" (DN12)	20
¾" (DN15)	30
1" (DN20)	40
1 ¼" (DN25)	55
1 ½" (DN32)	80
2" (DN40)	100
2 ½" (DN50)	120

Table 2: Torque resistance of union connections

If a construction is used to secure the union nut behind the liner, other than specified in the NEN 2542 and NEN 2544, an additional test shall be done as mentioned in paragraph 4.3.2 of this AR.

4.3.1 Test method

Fix the inlet side of the valve with appropriate connection facilities. Fix the union coupling on the outlet side by means of a swivel nut with a torsion moment according to table 2. Maintain this torsion moment for 10 sec. Remove the torsion moment and measure the external gas tightness according to EN 331, article 5.2.

4.3.2 Additional test

In case a construction is used as mentioned in paragraph 4.3, section 2, of this AR, the union nut shall be tightened with a torque of 6 Nm x DN size for 10 seconds. The nut will not be allowed to come loose from the liner. Remove the torsion moment and measure the external gas tightness according to EN 331, article 5.2.

4.4 Endurance

Contrary to EN 331:2015, clause 4.10.2.1, after the endurance test, the operating torque shall comply to the requirements given in clause 4.2 of this AR.

4.5 Resistance to low temperature

Contrary to EN 331, article 4.10.2.2, the operation torque shall conform to the requirements given in paragraph 4.2 of this AR.

4.6 Resistance to high temperatures

The manually operated ball valves and closed bottom taper plug valves (including handle or knob with plastic cover, if applicable) shall be resistant to a radiation heat of 10 kW/m² during 30 minutes in open position. The leakage shall be ≤ 5 liters per hour after testing.

4.6.1 Test method

The test shall be performed at a temperature of 20 ± 5 °C. The test samples shall be conditioned at least 24h before testing at a temperature of 20 ± 5 °C and a relative humidity of 60 ± 20 %.

The test is performed in a horizontally test equipment as shown in figure 1. The leakage shall be measured in accordance with Annex A of EN 1775.

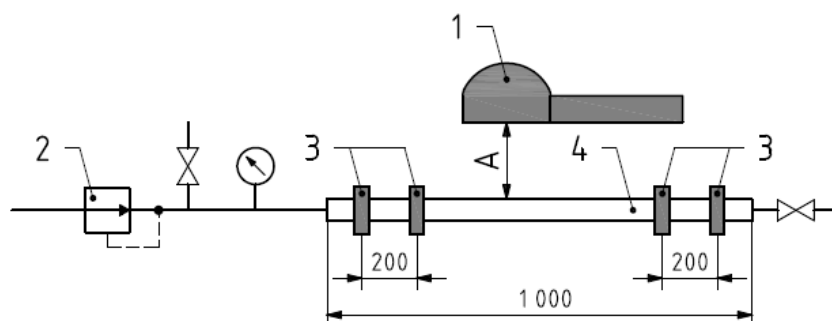

Figure 1

Legend:

1 heat cup

2 measuring system as described in appendix A of EN 1775:

3 mounting brackets

4 to be tested sample

A distance between heat cup and surface of the assembled component (for example the outside of a casing)

The test sample shall be mounted in the test equipment without stress or tension on the test sample, see figure 1.

Before the start of the high temperature test, the sample is tested on leakage at 200 mbar for 5 minutes. Record the leakage value (l/h).

Expose the test sample for 30 minutes to a heat radiation of 10 kW/m². The distance between the heating cup and the sample shall be calculated with the data on the calibration file of the heating cup.

Determine the leakage after the high temperature test during 5 minutes at 200 mbar. Record the value (l/h).

5 Marking, instructions and packaging

5.1 Marking

In addition to article 7.1 of EN 331: 2015 the housing of the valve and the connecting parts shall be clearly and durably marked with:

- GASTEC QA, GASTEC QA logo or punch mark.

5.2 Instructions

As stated in NEN-EN 331: 2015 article 7.2, the supplier shall provide instructions. These instructions shall also be provided in the Dutch language.

5.3 Packaging

Packaging shall comply with article 7.3 of NEN-EN 331: 2015

6 Quality system requirements

The requirements for the quality system are described in the GASTEC QA general requirements. An important part of this are the requirements for drawing up a risk analysis (e.g., an FMEA) of the product and the production process in accordance with chapters 3.1.1.1 and 3.1.2.1. This risk analysis shall be available for inspection by Kiwa.

7 Summary of evaluation

This chapter contains a summary of tests to be carried out during:

- The initial product assessment;
- The periodic product verification;

7.1 Evaluation matrix

Description of requirement	Clause EN 331	Test within the scope of		
		Initial product assessment	Product verification Verification	Frequency
Product requirements				
Materials	4.2.1	X	X	Once a year
Construction	4.2.2	X	X	Once a year
Product appearance	4.2.3	X	X	Once a year
Valve maintenance	4.2.4	X		
Springs	4.2.5	X		
Wall thickness	4.2.6	X	X	Once a year
Plug valves	4.2.7	X		
Angular seal	4.2.8	X		
Seals	4.2.9	X	X	Once a year
Operation	4.2.10	X		
Stops	4.2.11	X		
Joints	4.2.12	X		
Functional requirements				
Pressure classes	4.3.1	X	X	Once a year
Temperature classes	4.3.2	X	X	Once a year
High temperature resistance classes	4.3.3	X	X	Once a year
Tightness (gas): leak tightness	4.4	X	X	Once a year
Effectiveness: rated flow rate	4.5	X		
Resistance to high temperature	4.6	X		
Operating torque	4.7.1	X	X	Once a year
Torque and bending mechanical strength	4.7.2	X	X	Once a year
Safeguard against overloading of the handle – stop resistance	4.8	X	X	Once a year
Release of dangerous substances	4.9	X		
Endurance	4.10.2.1	X	X	Once a year
Resistance to low temperature	4.10.2.2	X		
Marking, labelling, instructions, and packaging	7	X	X	Once a year
Additional GASTEC QA requirements	Clause AR 69-1			
Nominal diameters	3.2	X		
Reaction to fire	3.3	X		
Operating	3.4	X		
Material of handle and knob	3.5	X	X	Once a year
Sealing of passages	3.6	X		
Rubber material	3.7	X	X	Once a year
Connections	3.8	X		
Leak tightness in locked position	4.1	X	X	Once a year
Operating torque	4.2	X	X	Once a year
Resistance against torsion on union connections	4.3	X		
Endurance	4.4	X	X	Once a year
Resistance to low temperatures	4.5	X		
Resistance to high temperatures	4.6	X		
Marking, instructions and packaging	5	X	X	Once a year

8 List of referenced documents and source

8.1 Standards / normative documents

All normative references in this Approval Requirement refer to the editions of the standards as mentioned in the list below.

EN 331: 2015	Manually operated ball valves and closed bottom taper plug valves for gas installations for buildings
EN 549: 2019 + A2:2024	Rubber materials for seals and diaphragms for gas appliances and gas equipment
EN 682: 2002 + A1: 2005	Elastomeric seals - Materials requirements for seals used in pipes and fittings carrying gas and hydrocarbon fluids
EN 1775: 2007	Gas supply - Gas pipework for buildings - Maximum operating pressure less than or equal to 5 bar - Functional recommendations
EN 10226-1: 2004	Pipe threads where pressure tight joints are made on the threads – Part 1: Taper external threads and parallel internal threads.
EN 15001-1: 2023	Gas Infrastructure - Gas installation pipework with an operating pressure greater than 0,5 bar for industrial installations and greater than 5 bar for industrial and non-industrial installations - Part 1: Detailed functional requirements for design, materials, construction, inspection and testing
NEN 1078: 2024	Supply for gas with an operating pressure up to and including 500 mbar - Performance requirements - New estate
NEN 2541: 1967	Fittings and connections for gas conduits
NEN 2542: 1967	Fittings and connections with outside thread for gas conduits
NEN 2544: 1967	Coupling nuts for fittings for gas and water conduits
NEN 2545: 1967	Packing rings for fittings for gas conduits
NEN 7244-10: 2021	Gas supply systems - Pipelines for maximum operating pressure up to and including 16 bar - Part 10: Specific functional requirements for housing for installations and housing for meters with a maximum inlet pressure of 100 mbar and a maximum design capacity of 650 m ³ _n /h
NPR 3378-11: 2018	Code of practice gas installations – Section gas pipe work – Part 11: Connecting pipe work and taps

8.2 Source of informative documents

EN 437: 2021	Test gases- test pressure – appliance categories
General requirements GASTEC QA	
Approval requirement 35	Compression fittings for joining copper pipes
Approval requirement 70	Mechanical fittings for plastic piping systems
Approval requirement 186	Press fittings for joining copper pipes