

AR 35

October 2024

Approval requirement 35

Compression fittings for joining copper pipes



Trust
Quality
Progress

Foreword

This approval requirement (AR) is approved by the Board of Experts (BoE) GASTEC QA, in which relevant parties in the field of gas related products are represented. This Board of Experts supervises the certification activities and where necessary require the GASTEC QA approval requirement to be revised. All references to Board of Experts in this GASTEC QA approval requirement pertain to the above-mentioned Board of Experts.

This AR will be used by Kiwa Nederland BV in conjunction with the GASTEC QA general requirements and the KIWA regulations for certification.

In this AR is established which requirements a product and the requestor/ certificate holder of the GASTEC QA product certificate should meet and the matter to which Kiwa evaluates this.

Kiwa has a method which is established in the certification procedure for the execution of:

- The investigation for provisioning and maintaining a GASTEC QA product certificate based on this AR.
- The periodic evaluations of the certified products for the purpose of maintaining a provided GASTEC QA product certificate based on this AR.

Approved by the Board of Experts: Month date, year

Accepted by Kiwa Nederland B.V.: Month date, year

Kiwa Nederland B.V.

Wilmersdorf 50
P.O. Box 137
7300 AC Apeldoorn
The Netherlands

Tel. +31 88 998 33 93
Fax +31 88 998 34 94
info@kiwa.nl
www.kiwa.nl

© 2024 Kiwa Nederland B.V.

All rights reserved. No part of this book may be reproduced, stored in a database or retrieval system, or published, in any form or in any way, electronically, mechanically, by print, photoprint, microfilm or any other means without prior written permission from the publisher.

The use of this approval requirement by third parties, for any purpose whatsoever, is only allowed after a written agreement is made with Kiwa to this end

Contents

Foreword	1	
Contents	2	
1	Introduction	4
1.1	General	4
1.2	Scope	4
2	Definitions	5
3	Material and product requirements	6
3.1	General	6
3.2	Materials	6
3.2.1	Copper/Tin alloys	6
3.3	Construction	6
3.3.1	Sealing	6
3.3.2	Transition fittings	6
3.3.3	Nominal diameter	7
3.3.4	Across flats	7
3.3.5	Adaptor fittings	7
3.3.6	Hardness of the compression ring	7
3.3.7	Internal support / insert	8
3.4	Additional requirements for compression fittings for annealed copper pipe	8
4	Performance requirements and test methods	9
4.1	General	9
4.1.1	Samples	9
4.2	Leak tightness under pneumatic pressure	9
4.2.1	Test method	9
4.3	Air tightness	10
4.3.1	Test method	10
4.4	Resistance to pull out	10
4.4.1	Test method	10
4.5	Leak tightness under static flexural force	11
4.5.1	Test method	11
4.6	Resistance against torsion	11
4.6.1	Test method	11
4.7	Resistance to assembly forces	12
4.7.1	Test method	12
4.8	Resistance to repeated assembly	13
4.8.1	Test method	13

4.9	Resistance to dynamic loads	13
4.9.1	Test method	13
4.10	Resistance to high temperatures	14
4.10.1	Test method	14
5	Marking and instructions	16
5.1	Marking	16
5.2	Instructions	16
6	Quality system requirements	17
7	Summary of evaluation	18
7.1	Evaluation matrix	18
8	List of referenced documents and source	20
8.1	Standards / normative documents	20
8.2	Source of informative documents	20

DRAFT

1 Introduction

1.1 General

This GASTEC QA approval requirement (AR) in combination with the GASTEC QA general requirements, is applied by Kiwa as the basis for the issuing and maintaining the GASTEC QA product certificate for compression fittings joining copper pipes.

With this product certificate, the certificate holder can demonstrate to his or her customers that an expert independent organization monitors the production process of the certificate holder, the quality of the product and the related quality assurance.

Next to the requirements established in this AR and the general requirements, Kiwa has additional requirements in the sense of general procedural requirements for certification, as laid down in the internal certification procedures.

This GASTEC QA approval requirement replaces the version of September 2019.

List of changes:

- These approval requirements have been fully reviewed textually and brought in line with the new version of EN 1254-2.
- The evaluation matrix in chapter 7 has been adjusted according to EN 1254-2.
- The AR is fully reviewed textually.
- Change of paragraphs.
- Update of list of referenced documents.

The product requirements are changed.

1.2 Scope

This approval requirement applies to compression fittings for joining half-hard copper pipes (R250) or annealed copper pipes (R220) according to GASTEC QA Approval Requirements 5 for application in gas installations with a maximum working pressure of 1 bar.

The compression fittings shall be used for domestic gas installations which come in contact with 2nd and 3rd family gasses according to EN 437.

The specific functional recommendations for application of these fittings are described in the requirements and measuring methods NEN 1078 and NEN 2078, as well as in the national and international norms and/or regulations.

2 Definitions

In this approval requirement, the following terms and definitions are applicable:

Board of Experts (BoE): The Board of Experts GASTEC QA.

Maximum operating pressure (MOP): Maximum pressure that a component is capable of withstanding continuously in service under normal operating conditions.

See also the definitions mentioned in the GASTEC QA general requirements.

DRAFT

3 Material and product requirements

This chapter contains the requirements for the properties of the raw materials, materials and semi-products used during the production of the products to be certified under this AR.

3.1 General

Compression fittings for joining copper pipes shall comply with the requirements specified in EN 1254-2 "Copper and copper alloys – Plumbing fittings – Part 2: Compression fittings for use with copper tubes".

Supplementary the following mentioned requirements shall be met:

3.2 Materials

The manufacturer shall declare in writing that the requirements below have been met.

3.2.1 *Copper/Tin alloys*

The fitting shall be made of copper/tin alloys which shall meet the requirements according to EN 1254-2 article 1.

Note: The copper or copper alloys, Registered by CEN/TC 133 or Specified in European copper and copper alloy product standards have been in use for such a long time that the resistance against corrosion after 50 years, according to NEN 1078, is plausible.

3.3 Construction

3.3.1 *Sealing*

The sealing shall be realized with a metal compression ring or cutting ring without any sealant or lubrication being applied during the assembly.

3.3.2 *Transition fittings*

3.3.2.1 *Connection with threads*

Gastight connection threads shall meet the requirements of EN 10226-1.

3.3.2.2 *Capillar soldering*

Capillar soldering shall be according to approval requirements 6.

3.3.3 Nominal diameter

Contrary to EN 1254-2, article 4.11 and EN 1254-20, table 9, only the following nominal diameters are applicable in this AR:

- DN 10
- DN 12
- DN 15
- DN 18
- DN 22
- DN 28
- DN 35
- DN 42
- DN 54
- DN 64
- DN 76.1
- DN 88.9
- DN 108

Remark:

The abovementioned pipe diameters are generally applied in the Netherlands and are therefore included in GASTEC QA approval requirements 5.

3.3.4 Across flats

In addition to EN 1254-2, article 4.16 the width of the coupling nut flats shall be according to ISO 272.

If the width is greater than 46 mm, the flats might also be eight-sided.

The height of the nut across flat shall be at least equal to the values given in table 1.

Flat width [mm]		Across Flat height [mm]
more than	up to and including	
	22	4
22	27	5
27	32	6
32	41	7
41	50	8
50	75	9
75		10

Table 1: Minimum height nut flats

3.3.5 Adaptor fittings

With adaptor fittings and reduced couplings, the transition shall be carried out gradually. The angle with the axis of the fitting part concerned shall be 60° at the maximum.

3.3.6 Hardness of the compression ring

The Vickers hardness of the compression ring measured according to ISO 6507-1, shall be within the values as stated by the manufacturer.

3.3.7 Internal support / insert

Compression fittings suitable for use of annealed copper tubes (R220) shall be provided with an internal support / insert. This support can be integrated to the fitting body or a loose part. The internal support shall be provided with means to control its position in the pipe.

3.4 Additional requirements for compression fittings for annealed copper pipe

If the fittings are already certified according to this AR in combination with half hard copper pipe (R250), for certification in combination with annealed copper tubes (R220) the following requirements shall be met:

- AR 35, Clause 3.3.7 Internal support
- AR 35, Clause 4.4 Resistance to pull-out
- AR 35, Clause 4.5 Leak tightness under static flexural force
- AR 35, Clause 4.6 Resistance against torsion
- AR 35, Clause 4.7 Resistance to assembly forces
- AR 35, Clause 4.9 Resistance to dynamic loads
- AR 35, Clause 5.2 Assembly instructions

4 Performance requirements and test methods

In addition to the requirements from EN 1254-2, the following requirements shall be met.

4.1 General

Unless otherwise stated all testing shall be carried out at a temperature of 23 ± 2 °C.

The accuracy of the measurements shall be according to table 2

		Temperature			
	Pressure	Time	>100 °C	-10 °C -100 °C	< -10 °C
Accuracy	5% Rdg	1 minute	5% Rdg	3 °C	5 °C

Table 2: accuracy of the measurements

4.1.1 Samples

3 fittings.

These samples shall be composed according to EN 1254-2, article 5.1.1 and the relevant clause of EN 1254-20.

The compression fittings shall be assembled according to the instructions from the manufacturer. The compression fitting shall be capable to fit at pipes with the normal and reduced wall thickness range as mentioned in the GASTEC QA Approval requirements 5.

All tests shall be performed in conjunction with the standard wall thickness pipes. Tests as mentioned in the paragraphs 4.4, 4.5, 4.7 and 4.8 shall be additionally performed in conjunction with the reduced wall thickness pipes.

4.2 Leak tightness under pneumatic pressure

Additionally, to EN 1254-2, article 4.2.3.1, the leak tightness under pneumatic pressure shall also be carried out with a pressure of 16 bar.

No leakage is allowed during the test.

4.2.1 Test method

The test shall be carried out according to article 5.2.2 of EN 1254-2 with a pressure of 16 bar. During the test check for leakage using a water bath.

4.3 Air tightness

A fitting assembly shall withstand an air pressure of 5 bar for 10 seconds. Afterwards the assembly shall be able to withstand an internal air pressure up to 3 bar at temperatures between -20 °C and +150 °C. No leakage is allowed during the test.

4.3.1 Test method

To determine the resistance against internal air pressure the test samples shall be included in an installation according to EN 1254-20, figure 10.

In this installation, the pressure required shall be realized with compressed air at the required test temperature. The samples shall be immersed in a suitable liquid at the required test temperatures.

The test is carried out as follows:

1. Apply to the fitting assembly an air pressure of 5 bar during 10 seconds.
2. Apply directly after an air pressure of 3 bar to the test samples at room temperature and keep this pressure up.
3. Immerse the test samples in water at room temperature for 900 seconds.
4. Keep the test samples at a temperature of $150 \pm 3^{\circ}\text{C}$ for 6 hours.
5. Immerse the test samples in a suitable liquid at a temperature of $150 \pm 3^{\circ}\text{C}$ for 900 seconds.
6. Keep the test samples at a temperature of $-20 \pm 3^{\circ}\text{C}$ for 6 hours.
7. Immerse the test samples in a suitable liquid at a temperature of $-20 \pm 3^{\circ}\text{C}$ for 900 seconds.

No leakage shall occur under these circumstances.

4.4 Resistance to pull out

After testing the samples according to EN 1254-2, article 4.2.1.2, the samples shall additionally be tested with an internal air pressure of 3 bar for five minutes. No leakage is allowed during the test.

4.4.1 Test method

Carry out the test as described in EN 1254-2, article 5.3.1.2 and EN 1254-2, clause 8 and apply an internal air pressure of 3 bar for 5 minutes.

4.5 Leak tightness under static flexural force

After testing the samples according to EN 1254-2, article 4.2.1.3, the samples shall additionally be tested with an internal air pressure of 3 bar for five minutes. No leakage is allowed during the test.

4.5.1 Test method

Carry out the test as described in EN 1254-2, article 5.3.1.3 and 5.2.2 and apply an internal air pressure of 3 bar for 5 minutes and verify for leakage.

Then subject these samples to the test as described in paragraph 4.6 of this AR.

4.6 Resistance against torsion

Compression fittings fitted to copper pipes must be able to withstand a torque applied at right angles to the central axis of the pipe at room temperature.

The test is carried out according to paragraph 4.6.1.

No damage or leakage may be detected, nor may the fittings shift from the original mounting position on the pipe.

4.6.1 Test method

For determining the resistance against torque strain the test samples shall be included in an installation which can apply the required moment with the test sample immersed in water at room temperature.

The required pressure can be realized with compressed air. The method of installation in the test installation is shown in figure 1.

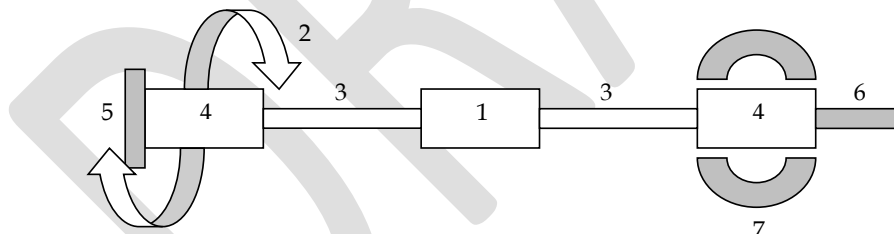

Figure 1: test installation

Legend:

- 1 = fitting to be tested
- 2 = torque
- 3 = copper pipe
- 4 = end fitting
- 5 = stop
- 6 = air pressure system
- 7 = clamp

Prior to testing the resistance against torsion, the test samples shall be tested according to paragraph 4.2 and 4.4 of this AR.

Working method for the resistance against torque:

1. Clamp the sleeve fittings in the testing installation.
2. Apply the required moment according to table 3 to one of the non-clamped fittings, perpendicular to the central axis of the copper pipe and maintain this moment.
3. Apply an air pressure of 3 bar to the test samples and maintain this pressure.
4. Immerse the test samples under water for 900 seconds.

No leakage shall occur during the test.

External diameter of copper pipe in millimetres	10	12	15	18	22	28	35	42	>42
Moment in Nm	10	12	15	18	22	28	35	42	50

Table 3: required moment

4.7 Resistance to assembly forces

Compression fittings shall be able to resist forces that arise because of tightening of the coupling nuts to a sufficient extent. After the test according to paragraph 4.7.1 of this AR, the fittings shall not show any damage or leakage.

4.7.1 Test method

Before and after this test, the fittings shall be tested for leak tightness according to EN 1254-2, article 4.2.3.1, with an internal water pressure of 16 bar, and an air pressure of 3 bar.

For determining the resistance to forces applied during assembly the test samples shall be placed in an installation according to EN 1254-20, figure 10.

In this set up, the test can be carried out at room temperature and in which it is possible to tighten the nut of the fitting.

The test is carried out as follows:

1. Determine the leak tightness of the joint according to paragraph 4.2.1 and 4.3.1 (steps 1 and 2).
2. Turn the nuts of the fitting another 180°.
3. Repeat step 1.

Before the test no leakage shall be visible, after the test no damage or leakage shall be visible.

4.8 Resistance to repeated assembly

After repeated assembly (25 times), the compression fittings shall not show signs of any leakage.

4.8.1 Test method

To determine the resistance to repeated assembly the test samples shall be included in an installation in which, during the assembly, the moment is determined that is required to tighten the coupling nuts and in which the integrity of the joint is measured at room temperature.

Three test samples are assembled according to EN 1254-2, article 5.1.1 and EN 1254-20, figure 10.

The test is carried out as follows:

1. Determine the maximum torque that is needed to install the coupling nuts of the sleeve joints according to the manufacturer's instructions.
2. Disassemble these joints.
3. Then assemble these joints by applying the moment determined by step 1).
4. Repeat step 2 and 3, 25 times.
5. Verify the leak tightness according to paragraph 4.3.1, steps 1 and 2.

4.9 Resistance to dynamic loads

This requirement only applies to fittings for use with annealed copper pipe (R220).

After the test no leakage shall be detected at an air pressure of 3 bar for 900 seconds. Also, the fitting is not allowed to displace.

4.9.1 Test method

The test sample is made of an end-fitting and the joints are made in accordance with the manufacturer instructions. The pipe length is 500 mm.

The fitting shall be exposed, at a temperature of 23 ± 2 °C, to a dynamic load of 1×10^6 cycles with a frequency of 10 Hz and amplitude according to table 4.

Pipe diameter (mm)	Amplitude (mm)
≤ 42	$3 \pm 0,5$
> 42	$2 \pm 0,5$

Table 4: Amplitude for dynamic load

The test is conducted as follows:

1. Put the assembly in an installation according to figure 2.
2. Apply the dynamic load.
3. Check after ending of the dynamic for leakage by means of leak detection solution.
4. Verify if the fitting has displaced.

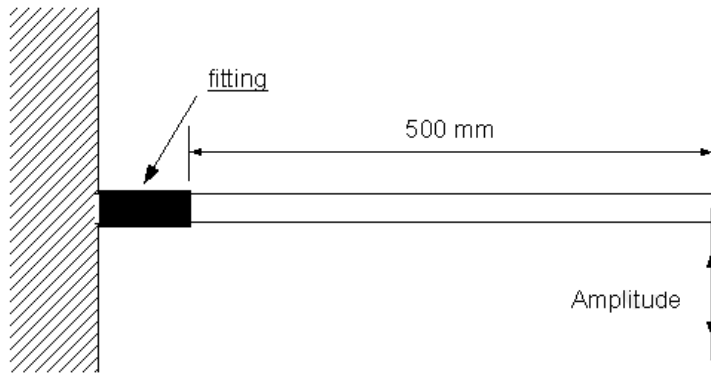

Figure 2: test assembly

4.10 Resistance to high temperatures

The compression fitting (including protection/isolation) shall be resistant to a radiation heat of 10 kW/m² for 30 minutes. The leakage shall be ≤ 5 liters per hour after testing.

4.10.1 Test method

The test shall be performed at a temperature of 20 ± 5 °C. The test samples shall be conditioned at least 24h before testing at a temperature of 20 ± 5 °C and a humidity of 60 ± 20 %.

The test is performed in a horizontally test equipment as shown in figure 3. The leakage shall be measured in accordance with Annex A of EN 1775.

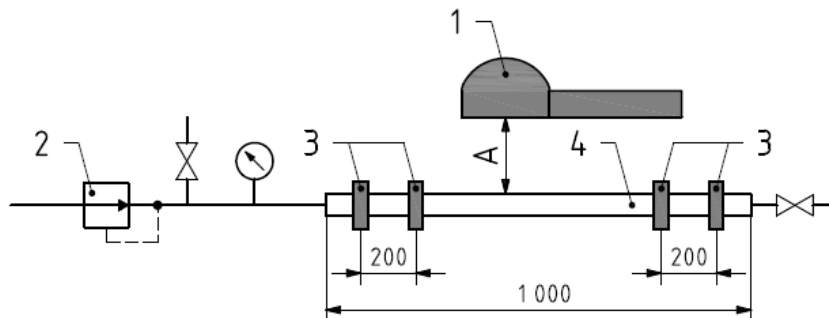

Figure 3

Legend:

1 heat cup

2 measuring system as described in appendix A of EN 1775

3 mounting brackets

4 to be tested sample

A distance between heat cup and surface of the assembled component (for example the outside of a casing)

The test sample shall be mounted in the test equipment without stress or tension on the test sample, see figure 3.

Before the start of the high temperature test, the sample is tested on leakage at 200 mbar for 5 minutes. Record the leakage value (l/h).

Expose the test sample during 30 minutes to a heat radiation of 10 kW/m². The distance between the heating cup and the sample shall be calculated with the data on the calibration file of the heating cup.

Determine the leakage after the high temperature test during 5 minutes at 200 mbar. Record the value (l/h).

DRAFT

5 Marking and instructions

5.1 Marking

In addition to EN 1254-2, article 8 the following marking shall be added.

- GASTEC QA, GASTEC QA logo or punch mark. This also applies for the inserts.
- This marking shall be placed on the fittings and the inserts for R220 copper pipes.
- The inserts are marked with the diameter x wall thickness.

5.2 Instructions

The manufacturer shall provide installation instructions. The installation instructions shall be provided in a language which can be easily understood and additionally also in the Dutch language.

These instructions shall at least contain the following:

- The tightening moment or the number of times the coupling nut must be tightened during the assembly.
- The necessity to use inserts when fittings are used in combination with R220 copper pipes.

6 Quality system requirements

The requirements for the quality system are described in the GASTEC QA general requirements. An important part of this are the requirements for drawing up a risk analysis (e.g., an FMEA) of the product design and the production process in accordance with chapters 3.1.1.1 and 3.1.2.1. This risk analysis shall be available for inspection by Kiwa.

DRAFT

7 Summary of evaluation

This chapter contains a summary of tests to be carried out during:

- The initial product assessment;
- The periodic product verification;

7.1 Evaluation matrix

Description of requirement (1)	Article EN 1254-2	Test within the scope of		
		Initial product assessment	Product verification Verification	Frequency
Scope	1	X		
Materials	1	X	X	Once a year
Product characteristics				
Internal pressure	4.1	X	X	Once a year
Tightness	4.2			
Integrity of fabricated fitting bodies or having an “as cast” microstructure	4.2.1.1	X		
Resistance to pull out	4.2.1.2	X		
Leak tightness under static flexural force	4.2.1.3	X		
Leak tightness under internal pneumatic pressure	4.2.3.2	X	x	Once a year
Leak tightness under temperature cycling for fuel gas applications	4.2.3.2	X		
Compression fitting with elastomeric seals for fuel gas inside buildings	4.2.3.3	X		
Release of dangerous substances	4.4	X		
Durability	4.5			
Durability of internal pressure: Resistance to stress corrosion	4.5.1	X		
Durability of tightness	4.5.2			
Resistance to dezincification	4.5.2.1	X		
Wall thickness of threaded portions of adaptor fittings	4.6	X	X	Once a year
Dimensions of tail pipe ends for swivel fittings	4.7	X	X	Once a year
Dimensions of gas union connectors	4.8	X	X	Once a year
Threaded end dimensions	4.9	X	X	Once a year
Other adapter ends	4.10	X	X	Once a year
Bore dimensions	4.11	X	X	Once a year
Identity of elastomeric sealing material	4.13	X		
Tube abutment	4.14	X	X	Once a year
Alignment of fitting ends	4.15	X	X	Once a year
Shapes for tightening systems	4.16	X	X	Once a year
Surface condition	4.17	X	X	Once a year
Plated or coated surfaces	4.18	X		
Designation	7	X		
Marking, labelling and packaging	8	X	X	Once a year

Description of requirement (2)	Article AR 35	Test within the scope of		
		Initial product assessment	Product verification	
			Verification	Frequency
General	3.1	X		
Materials	3.2	X	X	Once a year
Copper/Tin Alloys	3.2.1	X	X	Once a year
Construction	3.3	X		
Sealing	3.3.1	X		
Transition fittings	3.3.2			
Connection threads	3.3.2.1	X	X	Once a year
Capillar soldering	3.3.2.2	X		
Nominal diameter	3.3.3	X	X	Once a year
Across flats	3.3.4	X		
Adaptor fittings	3.3.5	X		
Hardness of the compression ring	3.3.6	X	X	Once a year
Internal support / inserts	3.3.7	X	X	Once a year
Leak tightness pneumatic pressure	4.2	X	X	Once a year
Air tightness	4.3	X	X	Once a year
Resistance to pull out	4.4	X		
Leak tightness under static flexural force	4.5	X		
Resistance against torsion	4.6	X		
Resistance to assembly forces	4.7	X	X	Once a year
Resistance to repeated assembly	4.8	X	X	Once a year
Resistance to dynamic loads	4.9	X		
Resistance to high temperatures	4.10	X		
Marking and instructions	5	X	X	Once a year

8 List of referenced documents and source

8.1 Standards / normative documents

All normative references in this Approval Requirement refer to the editions of the standards as mentioned in the list below.

EN 1254-2:2021	Copper and copper alloys - Plumbing fittings - Part 2: Compression fittings for use with copper tubes
EN 1775: 2007	Gas supply - Gas pipework for buildings - Maximum operating pressure less than or equal to 5 bar - Functional recommendations
EN 10226-1: 2004	Pipe threads where pressure tight joints are male on the treads – Part 1 taper external threads and parallel internal threads.
ISO 272:1982	Fasteners -- Hexagon products -- Widths across flats
ISO 6507-1:2023	Metallic materials - Vickers hardness test – Part 1: Test method

8.2 Source of informative documents

EN 437: 2021	Test gases- test pressure – appliance categories
NEN 1078: 2024	Supply for gas with an operating pressure up to and including 500 mbar - Performance requirements - New estate
NEN 2078:2001	Requirements for industrial gas installations
GASTEC QA approval requirements 5	Copper tubes
GASTEC QA approval requirements 6	Plumbing fittings with ends for capillar soldering and/or threads connections
General requirements GASTEC QA	