

AR 206
July 2024

Approval requirement 206

Corrugated safety metal hose assemblies



**Trust
Quality
Progress**

Foreword

This approval requirement (AR) is approved by the Board of Experts (BoE) GASTEC QA, in which relevant parties in the field of gas related products are represented. This Board of Experts supervises the certification activities and where necessary require the GASTEC QA approval requirement to be revised. All references to Board of Experts in this GASTEC QA approval requirement pertain to the above-mentioned Board of Experts.

This AR will be used by Kiwa Nederland BV in conjunction with the GASTEC QA general requirements and the KIWA regulations for certification.

In this AR is established which requirements a product and the requestor/ certificate holder of the GASTEC QA product certificate should meet and the matter to which Kiwa evaluates this.

Kiwa has a method which is established in the certification procedure for the execution of:

- The investigation for provisioning and maintaining a GASTEC QA product certificate based on this AR.
- The periodic evaluations of the certified products for the purpose of maintaining a provided GASTEC QA product certificate based on this AR.

Approved by the Board of Experts: Month date, year

Accepted by Kiwa Nederland B.V.: Month date, year

Kiwa Nederland B.V.

Wilmersdorf 50
P.O. Box 137
7300 AC Apeldoorn
The Netherlands

Tel. +31 88 998 33 93
Fax +31 88 998 34 94
info@kiwa.nl
www.kiwa.nl

© 2024 Kiwa Nederland B.V.

All rights reserved. No part of this book may be reproduced, stored in a database or retrieval system, or published, in any form or in any way, electronically, mechanically, by print, photoprint, microfilm or any other means without prior written permission from the publisher.

The use of this approval requirement by third parties, for any purpose whatsoever, is only allowed after a written agreement is made with Kiwa to this end

Contents

	Foreword	1
	Contents	2
1	Introduction	3
1.1	General	3
1.2	Scope	3
2	Definitions	4
3	Product Requirements	5
3.1	General	5
3.2	Construction	5
3.2.1	Swivel/ rotary joint	5
3.2.2	Hose fitting design requirements	5
3.2.3	Rubber seals	6
3.2.4	Length	6
4	Performance requirements	7
4.1	General	Error! Bookmark not defined.
4.2	Torsion resistance including swivel/ rotary joint	7
5	Marking and instructions	8
5.1	Marking	8
5.2	Instructions	8
6	Quality system requirements	9
7	Summary of tests	10
7.1	Test matrix	10
8	List of referenced documents and source	11
8.1	Standards / normative documents	11

1 Introduction

1.1 General

This GASTEC QA approval requirement (AR) in combination with the GASTEC QA general requirements, is applied by Kiwa as the basis for the issuing and maintaining the GASTEC QA product certificate for corrugated safety metal hose assemblies.

With this product certificate, the certificate holder can demonstrate to his or her customers that an expert independent organization monitors the production process of the certificate holder, the quality of the product and the related quality assurance.

Next to the requirements established in this AR and the general requirements, Kiwa has additional requirements in the sense of general procedural requirements for certification, as laid down in the internal certification procedures.

This GASTEC QA approval requirement replaces the version of May 2019.

List of changes:

- The requirement for stress corrosion resistance is added
- Textual revision
- Update of definitions
- Update of referenced standards

The product requirements have not changed.

1.2 Scope

This AR applies to corrugated safety metal hose assemblies suitable for the connection of domestic movable or fixed appliances inside buildings according to NPR 3378-11. The corrugated safety metal hose assemblies shall be used for 1st, 2nd and 3rd family gasses according to EN 437, with a maximum operating pressure up to and including 0.5 bar.

2 Definitions

Austenitic stainless steel: Stainless steel (SS) is an iron alloy and has a high corrosive resistance. The addition of alloying elements provides specific properties. Austenitic stainless steel belongs to 1 of the 4 main groups of stainless steel. Austenitic stainless steel is characterized by nickel and chromium as the main alloying elements.

Board of Experts (BoE): The Board of Experts GASTEC QA.

Maximum operating pressure (MOP): Maximum pressure that a component is capable of withstanding continuously in service under normal operating conditions.

Stress corrosion: Type of corrosion caused by control stresses (via operations) and the simultaneous action of a corrosive medium. Stress corrosion cracking is a consequence of stress corrosion cracking.

Uniform corrosion: Type of corrosion due to a natural interaction between a material and its environment. Oxygen corrosion is the most visible form of corrosion.

See also the definitions mentioned in the GASTEC QA general requirements.

3 Material and product requirements

This chapter contains the requirements for the properties of the raw materials, materials and semi-products used during the production of the products to be certified under this AR (e.g., support bushes).

3.1 General

The products shall comply with the requirements as specified in EN 14800 “Corrugated safety metal hose assemblies for the connection to domestic appliance using gaseous fuels”.

In addition, the following requirements shall be met:

3.2 Construction

3.2.1 Swivel/ rotary joint

The corrugated metal hose (CMG hose) assemblies shall be provided with one or on both side(s) a swivel/ rotary joint, as described in paragraph 3.16 of the EN 14800.

3.2.2 Hose fitting design requirements

The CMG hose shall be provided with at least one fitting according to figure 1.

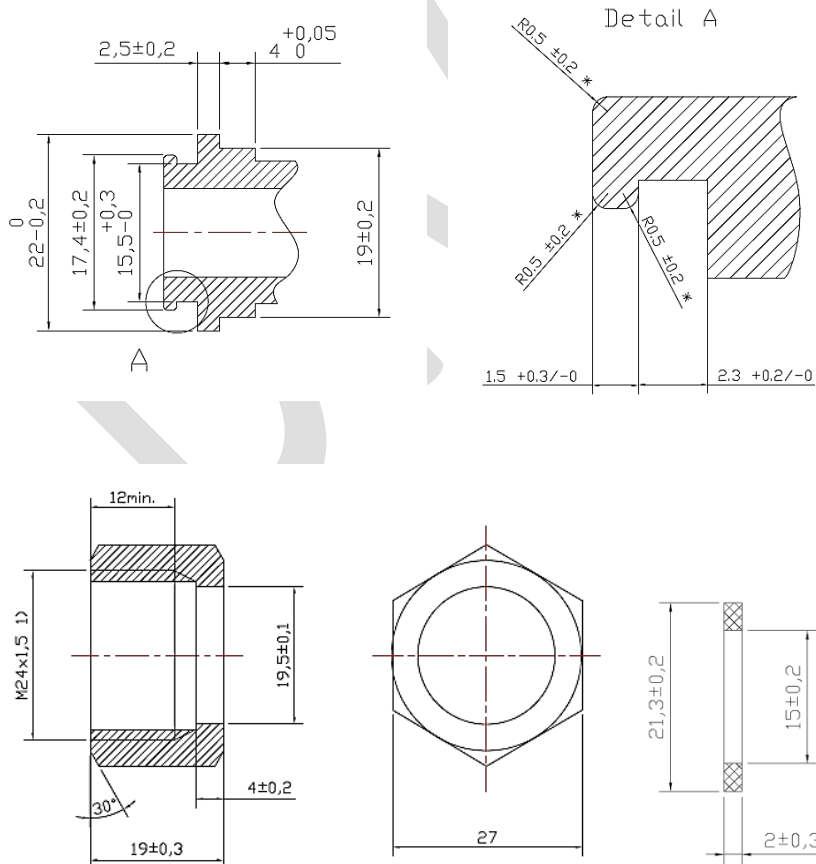

The other fitting shall comply with the relevant GASTEC QA approval requirements or when no GASTEC QA approval requirement is available with the relevant national or international standards.

When fittings are provided with a hexagonal nut, the wide of the across flats of the nut shall be according to ISO 4032.

3.2.3 Rubber seals

Rubber seals shall comply with EN 549, with a minimum temperature class of A2.

3.2.4 Length

The length of the CMG hose shall be between 200 mm and 600 mm \pm 20 mm. Lengths up to 2 meter are allowed with an additional remark on the packaging or instructions.

DRAFT

4 Performance requirements and test methods

In addition to the requirements from EN 14800, the following requirements shall be met.

4.1 Torsion resistance including swivel/ rotary joint

The torsion resistance test, as described in paragraph 5.16 of EN 14800, shall be performed with the swivel/ rotary joint in both the locked and unlocked position.

4.2 Stress corrosion resistance

All parts shall be resistant to stress corrosion.

For stainless steel parts the magnesium chloride test shall be performed according to paragraph 4.2.1. After exposure there shall be no visual signs of cracks using a magnification of 5 times.

Parts made from copper alloys shall be tested by an ammonium chloride test according to ISO 6957 (pH 9.5). No visual signs of cracks shall be observed with a magnification of 10 to 15 times.

4.2.1 Testmethod

The parts shall be degreased using acetone.

Dissolve 1000 g of $MgCl_2 \cdot 6H_2O$ for every 500 ml of distilled water or proportional parts thereof. There shall be sufficient liquid to submerge the entire part and to suspend it freely from the bottom in the test vessel.

Heat the test vessel up to 130 ± 2 °C and position the part in the liquid for 108 hours and, next, allow the liquid to cool down to 70 ± 2 °C. Keep the sample at this temperature for 60 hours.

It can be necessary that a small amount of magnesium chloride or distilled water must be added in order to reach the 130 °C. Make sure that the heating takes place uniformly (avoid bumps and jolts).

The visually assessment of the CMG takes place with the aid of a 5x magnifying glass.

5 Marking and instructions

5.1 Marking

The products shall be marked according EN 14800, annex ZA.3 with the following additions:

- The GASTEC QA word mark or logo shall be marked on the product.
- The year of manufacture shall be permanently marked on the CMG hose assembly.

The marking shall be permanent, clearly, and indelibly. The method of marking shall not damage or corrode in any way the corrugated hose and the fitting.

5.2 Instructions

The installation instructions shall be provided in the Dutch language. On or inside the packaging the following text shall be provided in the Dutch language:

- Prevent all kind of damages during installation (Dutch: Voorkom iedere beschadiging tijdens montagewerkzaamheden)
- Make sure the hose is not twisted after installation (Dutch: Zorg er voor dat de leiding niet wordt gewrongen)
- The hose shall be installed without narrow bendings (Dutch: Leg de leiding zodanig dat er geen scherpe knikken ontstaan)

6 Quality system requirements

The requirements for the quality system are described in the GASTEC QA general requirements. An important part of this are the requirements for drawing up a risk analysis (e.g., an FMEA) of the product and the production process in accordance with chapters 3.1.1.1 and 3.1.2.1. This risk analysis shall be available for inspection by Kiwa.

DRAFT

7 Summary of tests

This chapter contains a summary of tests to be carried out during:

- The initial product assessment;
- The periodic product verification;

7.1 Test matrix

Description of requirement	Clause EN 14800	Test within the scope of		
		Initial product assessment	Product verification	
			Verification	Frequency
Construction requirements	4			
General	4.1	X		
Nominal size	4.2	X		
Materials	4.3	X		
Requirements for the connection between hose and fittings	4.4	X		
End fittings design requirements	4.5	X		
CMG hose assembly lengths	4.6	X	X	1x/ year
Corrosion requirements	4.7	X		
Insulation requirements	4.8	X		
Electric conductivity requirements	4.9	X		
Hygiene	4.10	X		
Cover materials	4.11	X		
Dangerous substances	4.12	X		
Performance requirements and tests	5			
Leak tightness	5.3	X	X	1x/ year
Structural strength	5.4	X	X	1x/ year
Flow rate	5.5	X		
Electric continuity	5.6	X		
Tension	5.7	X		
Durability of marking	5.8	X		
Working temperature	5.9	X		
Corrosion resistance	5.10	X		
Reaction to fire	5.11	X		
Resistance to high temperature	5.12	X		
Suppleness	5.13	X		
Bending performance	5.14	X		
Flexing resistance	5.15	X		
Torsion resistance	5.16	X		
Impact / crushing resistance	5.17	X		
Penetration resistance	5.18	X		
End fittings	5.19	X		
Evaluation of conformity	6			
Installation instruction	6.4	X		
Packaging	6.5	X		
GASTEC QA approval requirement 206				
Swivel/ rotary joint	3.2.1	X		
Hose fitting design requirements	3.2.2	X	X	1x/ year
Rubber seals	3.2.3	X		
Length	3.2.4	X	X	1x/ year
Torsion resistance including swivel/ rotary joint	4.1	X	X	1x/ year
Stress corrosion resistance	4.2	X	X	1x/ year
Marking and instructions	5	X	X	1x/ year

8 List of referenced documents and source

8.1 Standards / normative documents

All normative references in this Approval Requirement refer to the editions of the standards as mentioned in the list below.

EN 549: 2019+A1:2023	Rubber materials for seals and diaphragms for gas appliances and gas equipment
EN 14800: 2007	General requirements for corrugated safety metal hose assemblies for the connection of domestic appliance using gaseous fuels
ISO 4032: 2023	Hexagon regular nuts (style 1) – product grades A and B
ISO 6957: 1988	Copper alloys – ammonia tests for stress corrosion resistance
ISO 9227: 2022	Corrosion tests in artificial atmospheres – Salt spray tests

8.2 Source of informative documents

EN 437: 2021	Test gases- test pressure – appliance categories
NPR 3378-11: 2018	Code of practice gas installations – section gas pipe work- Part 11: connecting pipe work and taps
General requirements GASTEC QA	